

Linking your system

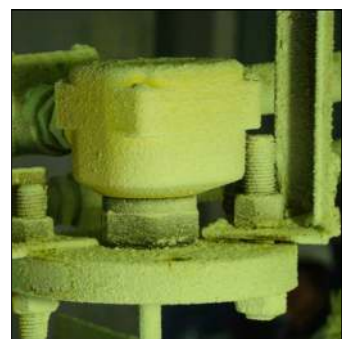

### Rotating Paddle Level Switches



The paddle of rotating paddle level switch is connected with clutch through shaft, the motor keep working when the paddle do not contact with material, and the motor will stop working when the paddle contact the material, at the same time, the electric instrument will send out a signal to measure the level of material, an indicator can also be installed to show the status of level switch.



www.ema-electronic.com

### Product Features



- Modular rotating paddle level switches:
- Unique oil-seal design can avoid dust infiltrate along the shaft
  - Stable and reliable torque, and the torque can be adjusted
  - Double bearing design, high loading strength
  - Stainless steel shaft and metal reduction gear parts to ensure the strength and life of motor system
  - Easy to check and maintain internal parts without dismantling from tank
  - Able to detect small specific gravity material

### Operating principle

The paddle of rotating paddle level switch is connected with clutch through shaft, the motor will keep working when the paddle do not contact with material, and the motor will stop working when the paddle contact the material, at the same time, the electric instrument will send out a signal to measure the level of material, an indicator can also be installed to show the status of level switch.

### Product Features

Rotating paddle level switch is suitable for environmental protection, water treatment, electricity, chemical plastic, pharmacy, fodder, cement, chemical fertilizer, food industrial, etc.



Radar Wave Level Sensors

Guided Radar (TDR)

Ultrasonic Level Sensors

Rotating Paddle Level Sensors

Vibrating Fork Level Switches

Float Level Switches

Capacitive Level Switches

**Trend of modular rotating paddle level switch**

1. The users can assemble them due to different length and demands
2. Reduce the package and freight cost
3. Lower inventory
4. Shorten the delivery time, create more business opportunities
5. Reduce the maintenance cost, and change any parts of the instruments at will

**Drawing Of Modular Type**

How to order modular type?

A	Main part
+	
B	Coupling
+	
C	Extension
+	
D	Process Connection (optional)
+	
E	Paddle

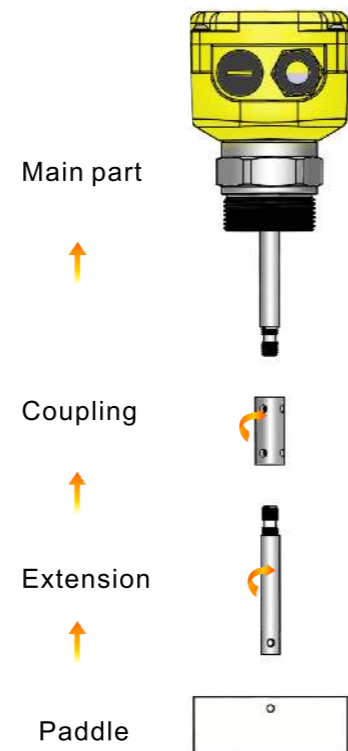

**Modular type of extension shaft length**

(Unit:mm)

Main Part shaft length	Extension shaft length	Total length
50	150	200
	350	400
	550	600
	750	800
	950	1000
	1150	1200

**Housing material**

■ Metal house is sturdy and durable . Please select metal housing for high temperature type.



**Circuit principle**

1. When the motor is on, C.L circuit closed means no resistance on paddle. When the motor is off, C.L circuit will be opened, meanwhile, C.H circuit closed means being resistance on paddle.
2. When operating without resistance, C.L circuit is closed and the motor start to work again.

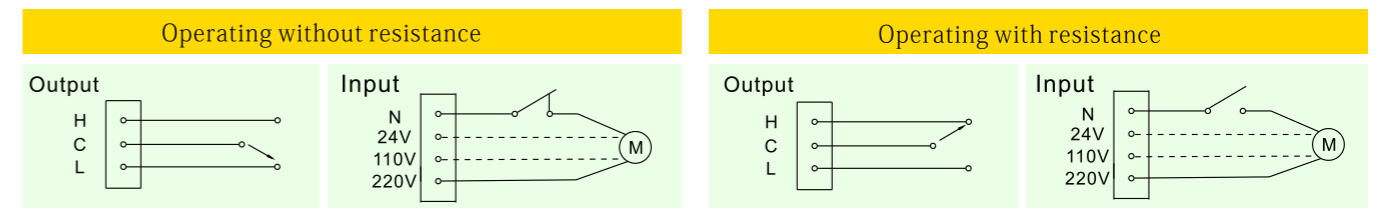

**Torque adjustment**

Torsional spring is used to adjust the torque of rotating axis. The torsional spring can be set at strong position on measuring heavy solid, while the paddle is poor sensitive. Reversly it can be set at weak position on measuring light bulk solid, while the paddle is sensitivity. To shaft gear, open the bottom and then clip the torsional spring by a nose plier. Finally, move the torsional spring to the position matching the torque desired.

Notice: Please don't set the torque of torsional spring randomly to avoid the false operation.

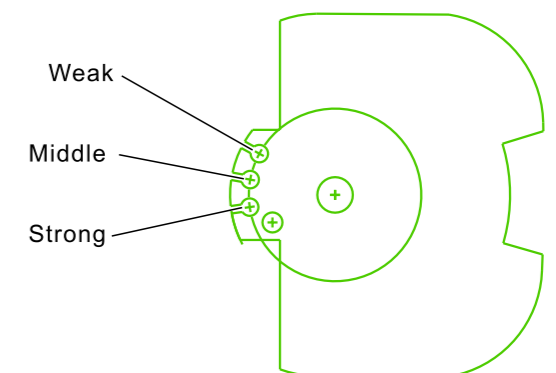

Radar Wave Level Sensors  
Guided Radar (TDR)  
Ultrasonic Level Sensors  
Rotating Paddle Level Sensors  
Vibrating Fork Level Switches  
Float Level Switches  
Capacitive Level Switches

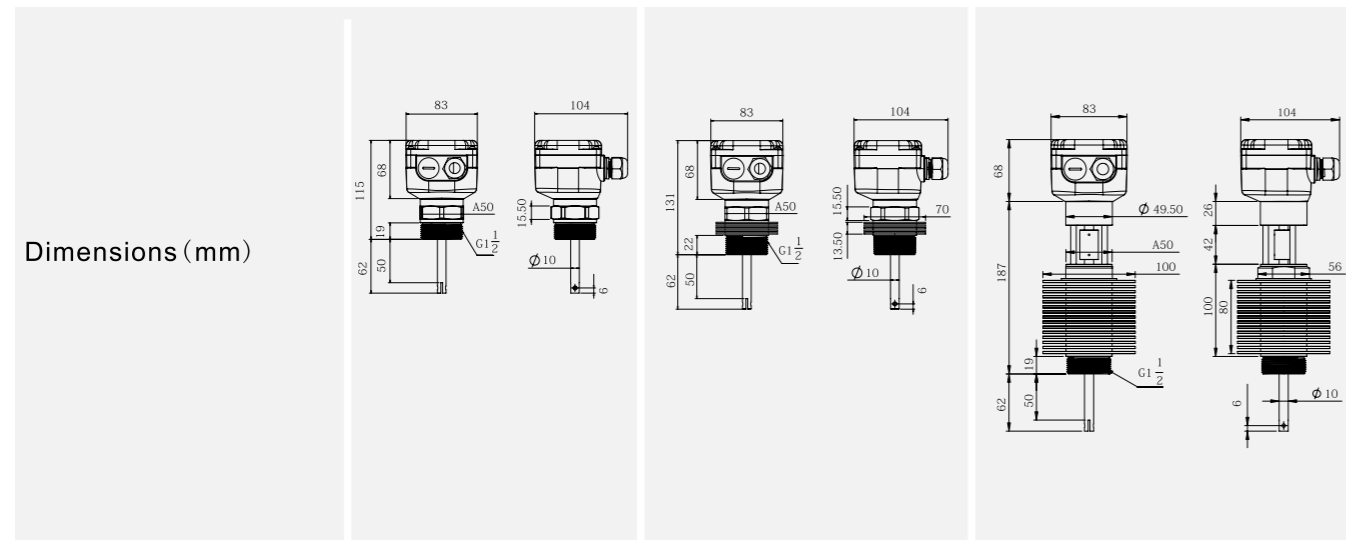

<b>Dimensions (mm)</b>			
<b>Model</b>	SRP10/SRT10	SRP20/SRT20	SRT30
<b>Type</b>	Standard	High temperature	Ultra-temperature
<b>Cable entrance</b>	M20xP1.5		
<b>Detecting medium</b>	Powder/Solid		
<b>Power supply</b>	24,110-120,220-240VAC/50-60Hz		
<b>Applications</b>	Chemical plastic, pharmacy, fodder, cement, chemical fertilizer, food industry, etc.		
<b>Power consumption(W)</b>	3		
<b>Torque measurement(Kgf.cm)</b>	0.5...1.0		
<b>Appropriate specific gravity (g/cm³)</b>	0.5		
<b>Contacting rating</b>	SPDT 5A/250VAC		
<b>Paddle rotational speed</b>	≤2 (RPM)		
<b>Medium density</b>	≥0.5g/cm³		
<b>Sensitivity</b>	Weak,Middle,Strong-3 level adjustable		
<b>Output</b>	Switching signal		
<b>Reliability</b>	No failure time is not less than 15,000 hours of continuous operation, >10000 times continuous operations		
<b>Drop</b>	Safe drop height ≤ 1.2M		
<b>Length of main part shaft (mm)</b>	50		
<b>Storage temperature</b>	-20~80°C		
<b>Operating temperature</b>	-20~80°C	MAX200°C	MAX450°C
<b>House material</b>	ABS/Aluminium	PA66/Aluminium	Aluminium

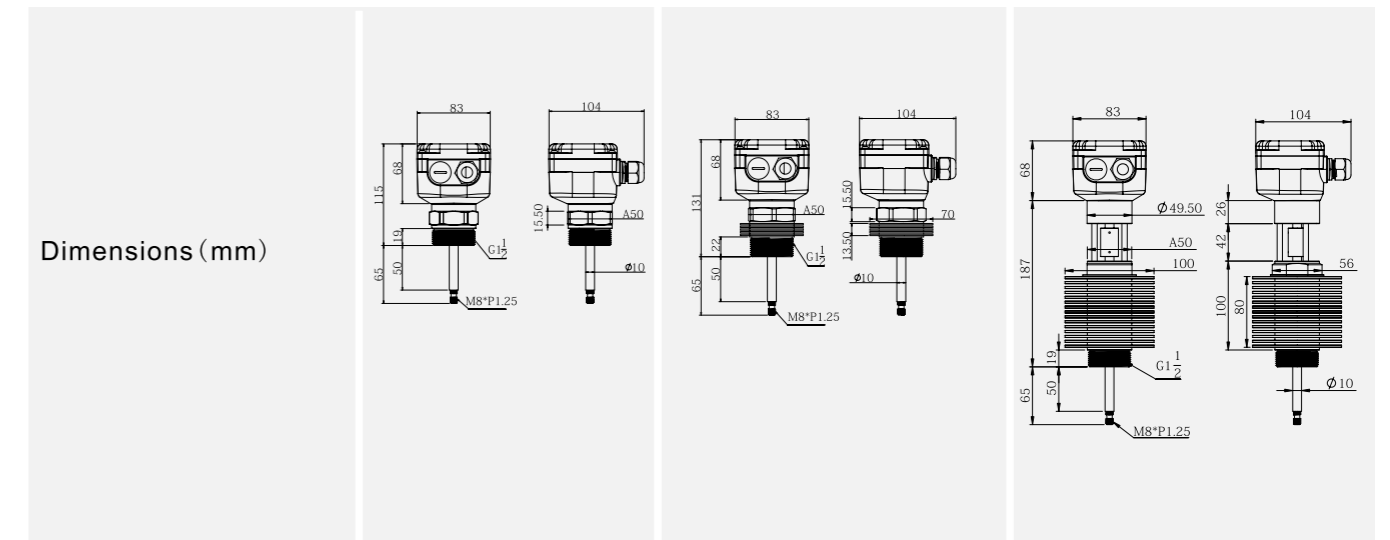

<b>Dimensions (mm)</b>			
<b>Model</b>	SRP11/SRT11	SRP21/SRT21	SRT31
<b>Type</b>	Modular Standard	Modular high temperature	Modular ultra-high temperature
<b>Cable entrance</b>	M20xP1.5		
<b>Detecting medium</b>	Powder/Solid		
<b>Power supply</b>	24,110-120,220-240VAC/50-60Hz		
<b>Applications</b>	Chemical plastic, pharmacy, fodder, cement, chemical fertilizer, food industry, etc.		
<b>Power consumption(W)</b>	3		
<b>Torque measurement(Kgf.cm)</b>	0.5...1.0		
<b>Appropriate specific gravity (g/cm³)</b>	0.5		
<b>Contacting rating</b>	SPDT 5A/250VAC		
<b>Paddle rotational speed(RPM)</b>	≤2		
<b>Medium density(g/cm³)</b>	≥0.5		
<b>Sensitivity</b>	Weak,Middle,Strong-3 level adjustable		
<b>Output</b>	Switching signal		
<b>Reliability</b>	No failure time is not less than 15,000 hours of continuous operation, >10000 times continuous operations		
<b>Drop</b>	Safe drop height ≤ 1.2M		
<b>Storage temperature</b>	-20~80°C		
<b>Operating temperature</b>	-20~80°C	MAX200°C	MAX450°C
<b>House material</b>	ABS/Aluminium	PA66/Aluminium	Aluminium

Notice: Extension shaft and steel wire can be selected as extension type connection part, please refer to P96.

Radar Wave Level Sensors  
Guided Radar (TDR)  
Ultrasonic Level Sensors  
Rotating Paddle Level Sensors  
Vibrating Fork Level Switches  
Float Level Switches  
Capacitive Level Switches

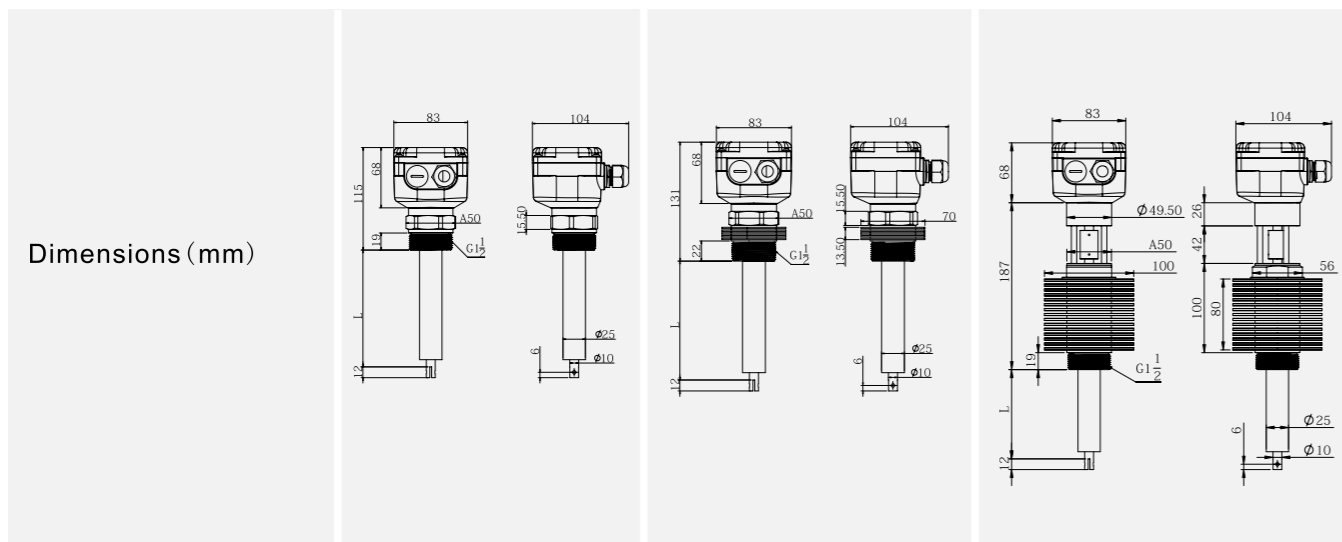

Model	SRP50/SRT50	SRP60/SRT60	SRT70
Type	Shaft protection	High temperature Shaft protection	Ultra-high temperature shaft protection
Cable entrance	M20xP1.5		
Detecting medium	Powder/Solid		
Power supply	24,110-120,220-240VAC/50-60Hz		
Applications	Chemical plastic, pharmacy, fodder, cement, chemical fertilizer, food industry, etc.		
Power consumption(W)	3		
Torque measurement(Kgf.cm)	0.5...1.0		
Appropriate specific gravity (g/cm³)	0.5		
Contacting rating	SPDT 5A/250VAC		
Paddle rotational speed(RPM)	≤2		
Medium density(g/cm³)	≥0.5		
Sensitivity	Weak,Middle,Strong-3 level adjustable		
Output	Switching signal		
Reliability	No failure time is not less than 15,000 hours of continuous operation, >10000 times continuous operations		
Drop	Safe drop height ≤ 1.2M		
Storage temperature	-20~80℃		
Operating temperature	-20~80℃	MAX200℃	MAX450℃
House material	ABS/Aluminium	PA66/Aluminium	Aluminium

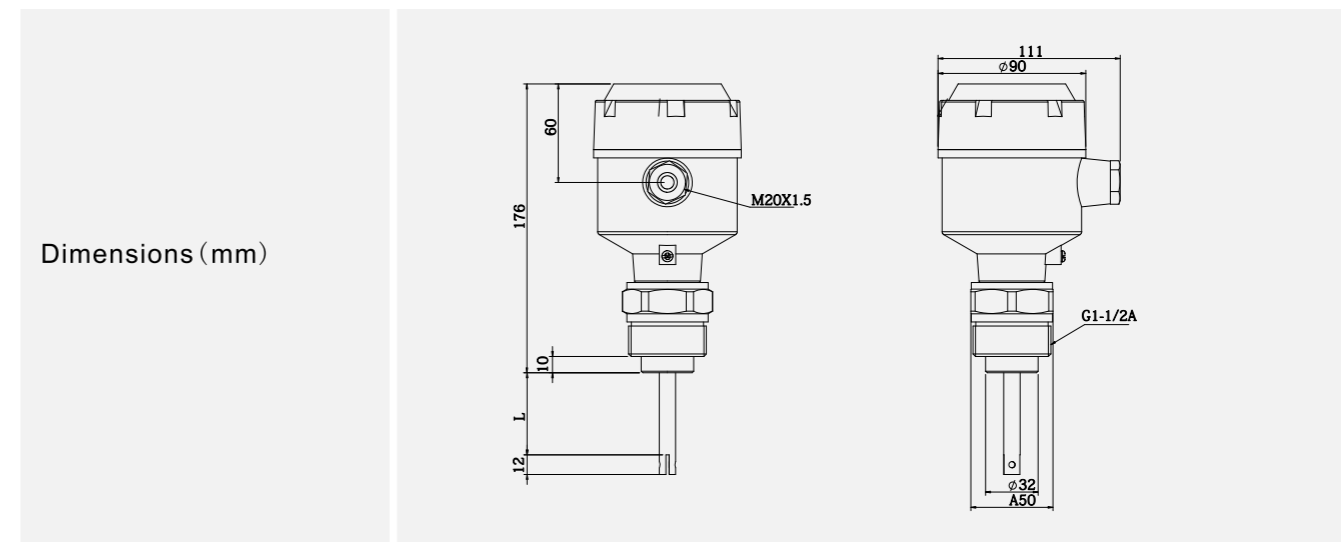

Model	SRE
Type	EX-proof
Cable entrance	M20xP1.5
Detecting medium	Powder/Solid
Power supply	24,110-120,220-240VAC/50-60Hz
Applications	Chemical plastic, pharmacy, fodder, cement, chemical fertilizer, food industry, etc.
Power consumption(W)	3
Torque measurement(Kgf.cm)	0.5...1.0
Appropriate specific gravity (g/cm³)	0.5
Contacting rating	SPDT 5A/250VAC
Paddle rotational speed(RPM)	≤2
Medium density(g/cm³)	≥0.5
Sensitivity	Weak,Middle,Strong-3 level adjustable
Output	Switching signal
Reliability	No failure time is not less than 15,000 hours of continuous operation, >10000 times continuous operations
Drop	Safe drop height ≤ 1.2M
Length of main part shaft(mm)	50
Operating temperature	-20~40℃
House material	Aluminium

Radar Wave Level Sensors

Guided Radar (TDR)

Ultrasonic Level Sensors

Rotating Paddle Level Sensors

Vibrating Fork Level Switches

Float Level Switches

Capacitive Level Switches

Order Info for rotating paddle level switch

SR	P	10	C	B	0050	4
Series	Housing material	type	connection	power supply	main shaft length	shaft material
<b>SR</b>	Standard rotating paddle level switch			Shaft-protection rotating paddle level switch		
<b>P</b>	Housing material : P: plastic housing T: metal housing (aluminium alloy )			Housing material : P: plastic housing T: metal housing (aluminium alloy )		
<b>10</b>	Type : 10: standard 80°C 20: high temperature Max 200°C 30: extremely high temperature Max 450°C 11: modular standard 80°C 21: modular high temperature Max 200°C 31: modular ultra-high temperature Max 450°C			Type : 50: shaft-protection standard 60: high temperature shaft-protection Max 200°C 70: ultra-high temperature shaft protection Max 450°C		
<b>C</b>	Connection : A:3/4"PF B:G1" C:G1 1/2"			Connection : C:G1 1/2"		
<b>B</b>	Power supply : A: 24VAC B: 110-120VAC C: 220-240VAC D:24VDC			Power supply : A: 24VAC B: 110-120VAC C: 220-240VAC D:24VDC		
<b>0050</b>	Main shaft length(mm) 0050: L=50mm			Main shaft length(mm) 0200: L=200mm 0400: L=400mm 0600: L=600mm 0800: L=800mm		
<b>4</b>	Shaft material: 4: stainless 304 6: stainless 316			Shaft material: 4: stainless 304 6: stainless 316		

Notice:

1. If the shaft length of extension type more than 1200mm, please select steel wire, suit able for vertical installation.
2. Steel wire type is suitable for standard extension type, high temperature extension type, ultra-high temperature extension type.
3. Ultra-temperature type only suitable for metal housing.
4. Check the coupling/extension shaft/paddle material is the same.
5. Confirm voltage, 24VAC, 110-120VAC, 220VAC or 24VDC.
6. Check specific gravity of detected medium.
7. Check the paddle size whether to meet the flange of the hole of tank wall
8. The shaft length tolerance is within ±5mm.
9. Extension type order information include main part and coupling, please selectively purchase the paddle, extension shaft and other accessories.

Order Info for EX-proof rotating paddle level switch

SR	E	10	C	C	0050	4
Series	Housing material	type	connection	power supply	main shaft length	shaft material
<b>SR</b>	Rotating paddle level switch					
<b>E</b>	Housing material : E:EX-proof/Aluminum Alloy					
<b>10</b>	Type : 10: standard 80°C 20: high temperature Max 200°C 11: modular- standard 80°C 21: modular high temperature Max 200°C			Type : 50: Shaft with shaft-protection tube 60: high temperature with shaft-protection Max 200°C		
<b>C</b>	Connection : C:G1 1/2"			Connection : C:G1 1/2"		
<b>C</b>	Power supply : A: 24 VAC B: 110 VAC C: 220 VAC D:24VDC					
<b>0050</b>	Main shaft length(mm) 0050: L=50mm			Main shaft length(mm) 0200: L=200mm 0400: L=400mm 0600: L=600mm 0800: L=800mm		
<b>4</b>	Shaft material: 4: stainless 304 6: stainless 316					

Radar Wave Level Sensors

Guided Radar (TDR)

Ultrasonic Level Sensors

Rotating Paddle Level Sensors

Vibrating Fork Level Switches

Float Level Switches

Capacitive Level Switches

**Coupling**

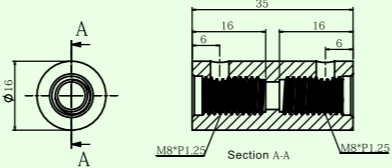
Order no	SS304	SS316	Drawing
	S4S0	S6S0	

**Extension shaft**

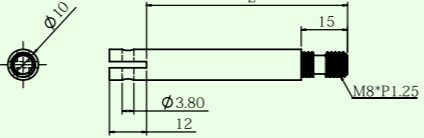
Order no	SS304	SS316	Drawing
	L40150: L=150mm L40350: L=350mm L40550: L=550mm L40750: L=750mm L40950: L=950mm L41150: L=1150mm	L60150: L=150mm L60350: L=350mm L60550: L=550mm L60750: L=750mm L60950: L=950mm L61150: L=1150mm	

**Wire**

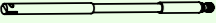
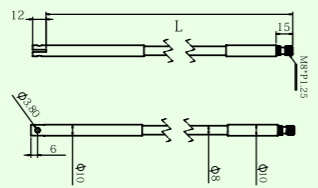
Order no	SS 304	Drawing
	W41500: L=1500mm W42000: L=2000mm W42500: L=2500mm W43000: L=3000mm	

- Notice:
1. Modular extension type need to be used with coupling, extension shaft and paddle. Please confirm that all materials are the same.
  2. Steel wire type need to be used with steel wire and paddle.

**Paddle**

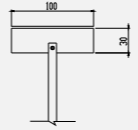
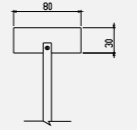
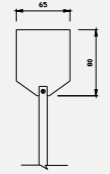
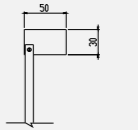
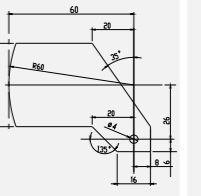
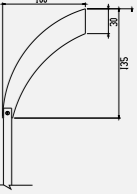
Order no	T1	T2	T3	L1	L2	N1
Drawing						
Stainless 304	S4T1	S4T2	S4T3	S4L1	S4L2	S4N1
Stainless 316	S6T1	S6T2	S6T3	S6L1	S6L2	S6N1
Dimension	100×30×1.8	80×30×1.8	65×80×1.8	50×30×1.8	60×40×1.8	100×30×1.8

**Connection**

Flange	SS 304	Drawing
	S4F0	
Fixture	#45 steel	Drawing
	S0C0	

Radar Wave Level Sensors

Guided Radar (TDR)

Ultrasonic Level Sensors

Rotating Paddle Level Sensors

Vibrating Fork Level Switches

Float Level Switches

Capacitive Level Switches

**Tank installation example**

**Standard mounting:**

Insert one side of the paddle to the hole of container by 35°, and turn it to right position slowly after the other side of the paddle passed through half of the wall-thickness.

**Fixture mounting :**

It is recommended to select sickle shape paddle to mount the switch with fixture. Please solder the fixture on the wall of the container and then insert the paddle to the G1-1/2"-n11 threads. Finally, screw it tightly.

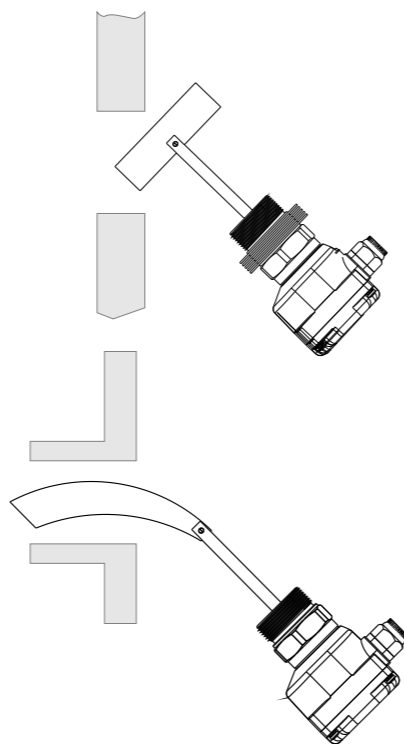

**Installation notice**

1. To reduce the shock of bulk solid, the switch can be mounted at 15°- 20° against the horizontal position when mounting it vertically in the side of the targeted object;
2. Please select high temperature type, when the temperature of targeted object is over 80°C.
3. The switch can be mounted directly without dismantling the paddles when select G1 1/2 fixture to mount it with a sickle shape paddle;
4. Make the connecting hole to cable headed below the instrumentation when mounting the switch vertically in the side of the targeted object. The nut which is used to fix the cable should be locked tightly in avoid of lacking. (As the figure above);
5. This product is prohibited from mounting at the entrance of the tank; however, please add an extra protection shield on this product to avoid the shock. The falling materials might affect the operation of this product if it is required to do so.
6. Please add a protection cover for the probe when detecting the cakes with the diameter over 15mm or when installing this product under the entrance of the tank by 7M.
7. Mount the switch vertically in the surface or the side of the targeted object. when detect sticky powder.

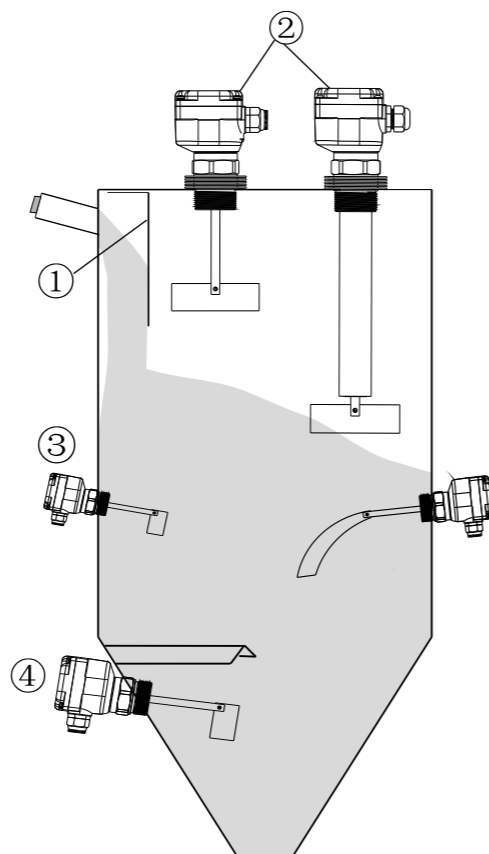

**Correct installation (as the right)**

- ① Protection plate for feedstock
- ② Enough room for installation and debugging
- ③ The angle of horizontal installation
- ④ Protection plate for low material entrance

**Wrong installation (as the right)**

- ① Too close to the wall of the tank and material, there do not have a protection plate at the entrance of material
- ② The distance between 2 and 3 is too close, will effect the installation and debugging
- ③ Please notice the angle of horizontal installation, and the connecting hole to cable should head below
- ④ There should add a protection plate for probe when detecting the cakes with the diameter over 15mm to avoid the destruction to switches close tightly to the wall of the container or of the pipe.

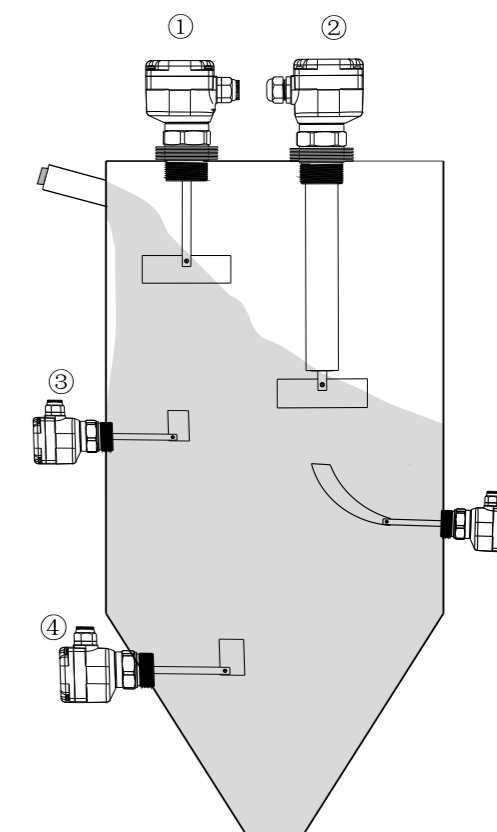

**Notice**

1. Make sure the mounting is based on the requirement conform to the restricted temperature, pressure, and other technical requirements.
2. Make sure the probe and the cable far away from the high voltage and such cable at least by 1 meter.
3. Make sure the airtightness of the module by adopting the circle cable which diameter is 6-7mm.
4. Make sure the wiring is correct and is close tightly to the wall of the container or of the pipe.

**Mounting type**

There are 5 mounting types available as following:

1. Standard mounting: Mount the switch directly by screwing tightly in the wall of the container which is applied to G1-1/2"-n11 threads.
2. Nut mounting: Vent the wall of the container (50mm < N < 78mm, N is the diameter of the vent), and then screwing it tightly with hexagon nut in the inner wall.
3. Flange mounting: Vent the wall of the container (78mm < N < 115mm, N is the diameter of the vent), and then fixed the flange on the wall of container with nuts.
4. Fixture mounting: Vent the wall of the container (N = 58mm, N is the diameter of the vent), and then fix it to the fixture. Finally, solder the fixture to the vent.
5. Adapter mounting: Link it to the adapter with G1-1/2"-n11 threads, and then link the adapter to the wall of the container. (The dimension of the thread for the adapter can be customized.)

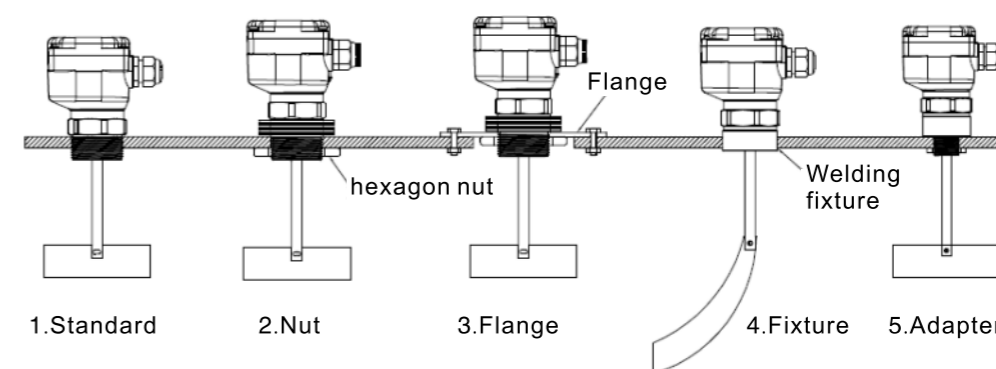

Radar Wave Level Sensors  
Guided Radar (TDR)  
Ultrasonic Level Sensors  
Rotating Paddle Level Sensors  
Vibrating Fork Level Switches  
Float Level Switches  
Capacitive Level Switches